

Wall Bracket Lensed E-Lamp "Pulse Start" Direct/Indirects: 50 to 150 Watt

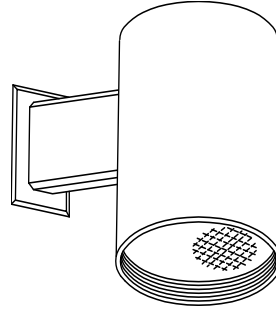

6" 100/100W **HWR-06147**
9" 150/150W **HWR-09148**

Features

Lamp

- Designed for medium base metal halide E-lamps. See chart below for standard and optional wattages.
- See Option -43 and chart below for lower wattage or HPS availability.

Sockets

- Vertical. Pulse rated. Glazed porcelain.
- Nickel-plated brass screw shell. Silicone leads.

Reflectors

- Specular parabolic or ellipsoidal Alzak® aluminum.

Trim Assemblies

- Direct: Seamless tapered black OptiGroove with white interlocking flange and UV absorbing tempered prismatic low brightness C#73 flat glass lens.
- Indirect: UV absorbing tempered prismatic C#73 flat glass on upper reflector.
- Optional lenses and trims available.

Ballast Assembly: Specify Voltage **HWR-06147**

- Regulating electronic high power factor, thermally protected encased and potted.
- Starting temperature -15°C.
- Wired for two circuits.
- Built-in RIF filter. THD is less than 10%.
- Sound rating A. Silicone leads.
- Dimming (-39) ballasts available. See Options.
- Cool, quiet, long-life.

Ballast Assembly: Specify Voltage **HWR-09148**

- WhisperPack™ fully encapsulated 180°C rated HPF pulse start ballasts.
- Premium Class H, high reactance for 120 volt; linear reactor for 277 volt.
- Capacitor and ignitor supplied.
- Wired for two circuits
- Dimming (-39) and electronic (-96) ballasts available. See Options.
- Cool, quiet, long-life. Silicone leads.

Fuse

- Fused primary. Renewable. Aids servicing. One per ballast. Not for 480 volt.

Housing

- White acrylic enameled rigid aluminum with wall bracket. No visible seam or hardware. See Options for other colors.
- Cool: Dissipates heat across entire surface.
- Rustproof: Exceeds 1000 hour ASTM 5% salt spray test.

Installation

- Wall bracket extrusion(s) assembled to housing. Wall plate included, for recessed outlet box.
- Mounting hardware included.
- Indoor or outdoor for covered ceiling use. (See Option -86)

UL, C-UL (Canada) Listings

- Wet, damp or dry locations, covered ceilings. (See Option -86)

Three Year Limited Warranty

- Complete standard fixture, including ballast

Wattage Availability

Catalog No.	Lamp/Base	Standard Wattage Direct/Indirect		Option -43: Lower Wattage		Max. Standby Wattage (-49-65-66-LS)	Lamp Position
		Pulse MH	-24 (HPS)	Pulse MH	-24 (HPS)		
HWR-06147	ED-17/Med	100/100	—	50-70	—	100	Vert/Vert
HWR-09148	ED-17/Med	150/150	150/150	50-125	35-100	100	Vert/Vert

Options

Sources and Ballasts

- 24 HPS ballast(s) instead. See wattage chart above for available wattages. Specify voltage.
- 39 Remote (10' max.) electronic dimming ballasts instead, for pulse start metal halide. Consult factory for wattage and voltage availability.
- 96 Remote (15' max.) electronic MH ballasts instead. Consult factory for internal mounting.

Wattage and Voltage

- 43 Lower wattage: See Option -43 chart above for available lower wattages. Specify voltage.
- 120 120 volt, 60 Hz. ballasts.
- 277 277 volt, 60 Hz. ballasts.
- 347 347 volt, 60 Hz. ballasts. Consult factory for dimming or electronic.
- 97 Other voltage ballast(s). Consult factory.

Relays, Standbys, Lamps (See Chart)

- 49 Extra circuit DCB socket. Do not energize simultaneously with main source. Also see -LS.

- 65 Electronic standby system and DCB socket. Following HID outage, provides immediate light until HID restrikes. Also see -66 and -LS.
- 66 Electronic time delay standby system and DCB socket. Following outage, provides light until HID reaches 70% output. Also see Option -LS.
- LP With lamp. Specify source, wattage, color temperature, and clear or coated. (3700°K standard for metal halide)
- LS With T-4 DCB tungsten halogen standby lamp. Use only with Options -49, -65 or -66.

Lenses and Trims (Direct Position Only)

- 27 Clear 1/4" tempered glass beneath tempered prismatic C#73 flat glass lens for impact resistance.
- 40 White grooveless flare trim assembly instead.
- 45 Gasket between trim and housing.
- 46 Gasket between trim and lens.
- FR Fresnel tempered lens instead.
- HO Holographic concave lens instead.
- ML UV absorbing tempered Microlux glass instead.

Luminaire (Housing) Finishes

- 35 Natural Aluminum enameled luminaire finish instead.
- 36 Gold enameled luminaire finish instead.
- 37 Dark Bronze enameled luminaire finish instead.
- 38 Black enameled luminaire finish instead.
- 94 Custom color luminaire finish. Consult factory.

Mounting Options

- 87 Custom wall bracket length. Specify or consult factory for available lengths.

Other Options

- 86 Gasketed prismatic glass WeatherCap for indirect position of luminaire; for installation in areas exposed to weather. Required for "Wet" label.
- 99 Special modification. Consult factory.

HWR-06147 HWR-09148

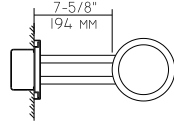

Plan View A

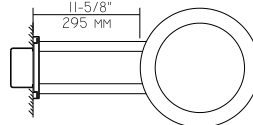

Plan View B

Cone of Light Key
Ft. Distance from fixture
FC Footcandles (average)
Dia. Circle of light at 50% of FC
 * Dia. (in ft.) shown is where FC value is half the FC at nadir.

C.U. (Coefficients of Utilization) Tables are available on request. Please contact your Kirlin representative.

HWR-06147 100/100W (Plan View A)

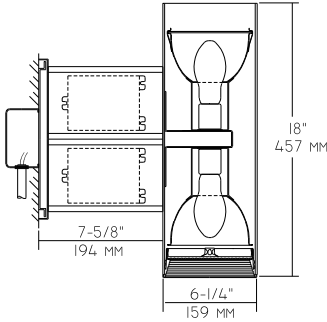

HWR-06147 (Clear Lamps)

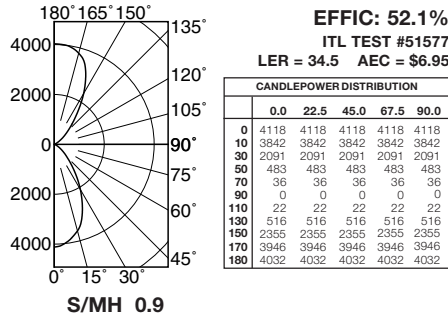

HWR-06147-FR (Clear Lamps)

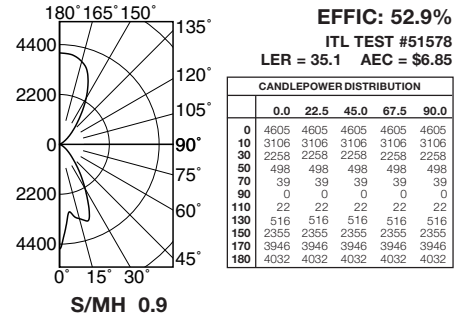

HWR-09148 150/150W (Plan View B)

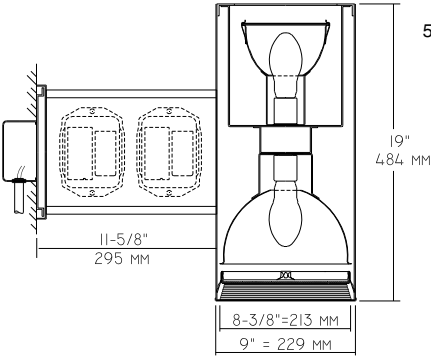

HWR-09148 (Clear Lamps)

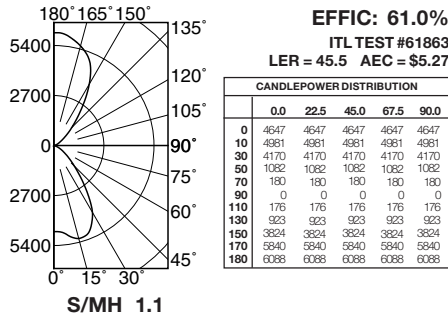

HWR-09148-FR (Clear Lamps)

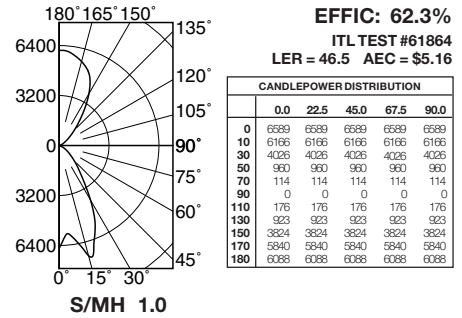

HWR-09148-HO (Clear Lamps)

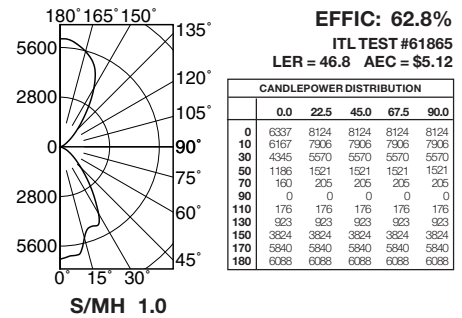

* **LER (Luminaire Efficacy Rating) = Luminaire Effic. x Total Lamp Lumens x Ballast Factor / Input Watts**

* **AEC = Annual Energy Cost per 1000 lumens (based on 3000 hours use @ \$.008 KWH).**

SUBMITTAL DATA

APPROVAL STAMP

JOB NAME _____
 TYPE _____
 WATTAGE _____ VOLTAGE _____
 CATALOG NUMBER _____

LIMITED WARRANTY: CATALOGED KIRLIN FIXTURES ARE WARRANTED FREE OF DEFECTS IN WORKMANSHIP OR MATERIAL FOR THREE YEARS FROM DATE OF PURCHASE. INSTALLATION TO N.E.C. IN NORMAL USE. Manufacturer at his option will replace or repair such fixture or return the purchase price on presentation of proof of purchase and defective fixture at the office of manufacturer within three years of original shipment. Liability of manufacturer is limited to the foregoing, and manufacturer shall not be liable for any other damages, direct or indirect, sustained or suffered by purchaser or others. This warranty is subject to the terms, conditions and limitations of the manufacturer's published literature. Kirlin Lighting Company reserves the right to modify or discontinue this warranty without notice. This warranty is void where prohibited by law.